

Cancer Tumour Detection In Brain Phantom Model By Microwave Imaging

Hemant Kumar Gupta¹, Ranjeet Singh Tomar², Shrashti Atre³, Mayank Sharma^{4*}

¹ Department of Electronics and Communication Engineering, School of Engineering and Technology, ITM University, Gwalior, Madhya Pradesh, India.

Email: hkgupta132@gmail.com

² Department of Electronics and Communication Engineering, School of Engineering and Technology, ITM University, Gwalior, Madhya Pradesh, India.

Email: er.ranjeetsingh@gmail.com

³ Malwa Institute of Science and Technology, Indore, Madhya Pradesh, India.

Email: sharshtiatre1102@gmail.com

⁴ Department of Electronics and Communication Engineering, School of Engineering and Technology, ITM University, Gwalior, Madhya Pradesh, India.

Email: mayanksintal@gmail.com

Corresponding Author: Hemant Kumar Gupta, hkgupta132@gmail.com

Abstract: Paper proposed ultra-wide band circular microstrip patch antenna is designed for interfacing with multilayer brain phantom model with spherical shaped tumour. Initially circular microstrip patch antenna (CMPA) is designed at 5.8GHz for ISM (Industrial scientific and medical band) to detect the tumour. Different types of defect ground structure (DGS) are applied to the CMPA to enhance its bandwidth. CMPA without DGS shows return-loss -10.66dB at 5.8GHz and bandwidth about 500MHz. CMPA with inverted E shaped slit-slot DGS shows return-loss -13.56dB and bandwidth 1.5GHz. Current density and SAR of the CMPA with DGS are 7.826A/m² and 84.19*10³ W/m³ respectively. Multilayer brain phantom model is designed on CST-MWS by considering the dielectric properties of the different layers of the brain as brain, CSF, dura, bone, fat, skin respectively. Designed brain phantom model is interfaced with CMPA with and without tumour. CMPA without tumour with multilayer brain phantom model shows return loss -14.54dB at 5.644GHz. Current density and SAR (Specific absorption rate) of the CMPA without tumour with multilayer brain phantom model is 450.7A/m² and 186e+03 W/m³ respectively. Spherical shaped tumour has been assumed by the 50mm radius and dielectric constant 50f/m and conductivity 4s/m respectively. CMPA interfaced with multilayer brain phantom model with tumour and it shows return-loss -13.45dB at 5.626GHz. Current density and SAR of the CMPA with multilayer brain phantom model and tumour is 1993A/m² and 484e+03W/m³ respectively. Increased values of the current density and SAR with tumour truly detect the early presence of tumour. Decline values of the return-loss with tumour also detect the early presence of tumour.

Keywords: Circular microstrip patch antenna (CMPA); Ultra-wide band (UWB); SAR (Specific absorption rate); CST-MWS (Computer simulation software-Microwave simulation software).

1. INTRODUCTION

Now day's tumours in the human are the biggest problem of the world. Detection of tumours in early stages is always challenging to the medical field. Although various method already available to detect the tumour like X-rays scanning, MRI etc. Disadvantage of these methods is repetition of these tests in human body may developed the various side effects. Microwave imaging uses a microwave frequency in the range of 300MHz-30GHz to detect the tumours, advantage of using microwave for tumour detection is safer option as compared to the other options. Repetition of test using microwave imaging is not harmful as compared to other methods. [1]-[2]. Microwave sensor used as a detection of tumour in different body parts of the human by changing in dielectrics of human tissues.[3] Authors Presented a different type of tumours and their early detection using microwave imaging [4]. Author presented



a ultra-wide band circular microstrip patch antenna for microwave imaging, antenna having a size of $37 \times 54.5 \times 1.6 \text{ mm}^3$ [5]. Author uses a microwave imaging to detect the tumour in human head model using CSW-MWS simulation software. Proposed antenna scans 9 different points in human head model. Matrix laboratory software used to analyse the s-parameter in frequency domain. Author detects the presence of tumours in head with lower reflection coefficient. [6]. Author proposed a method to reducing the reflection of the signal from the breast skin by placing the antenna in contact with the breast. Microwave imaging uses a low power and longer wavelength as compared to the x-ray mammography. [7] Multilayer concept of four layers has been proposed to detect the tumours in the human brain. Signal is applied to the human head model and reflected signal from brain has been analysed to detect the tumour by various scan methods. [8]. Author proposed an array of Vivaldi antenna to detect the tumour in the human head model. Proposed model with multilayer brain phantom model is presented and array of Vivaldi antenna is used to detect the spherical shaped tumour of 5mm radius. [9]. Author proposed a method to detect the tumour of less than 03mm. Ultra-wideband radar microwave image has been proposed for brain stroke detection. Frequency time domain time algorithm has been applied to detect the tumour in the human head [10]. Skin layer considered one of layer of the breast skin so that signal reflected only from the affected part. ANSOFT simulation software used to detect the tumour in the head, two models have been compared to detect the tumour in the breast [11]. Ultra-wide band planner antenna has been suggested to detect the tumour in the brain by microwave imaging. Simulation software CST and HFSS are used compare the result [12]. Tumour in the breast phantom model is detected by the variation in current density of planner antenna [13]. The Paper proposed a hybrid mode semicircular frequency reconfigurable antenna for multiband communication antenna having a size of $40 \text{ mm} \times 30 \text{ mm}$. Antenna covering a 3.89GHz-12.94GHz with peak gaining at 6.93dBi, proposed antenna can be used for WiMAX and Radar applications. [14]. Proposed antenna designed for CubeSat application, antenna is compact triband omnidirectional antenna working at 755GHz, L-band(1.25GHz), S-band(2.28GHz-3.74GHz) [15]. Article proposed a Ultrawideband miniature radiator tailored for microwave applications. Antenna having a size of $13 \times 14 \times 1.5 \text{ mm}^3$ antenna exhibit a 121.8% impedance bandwidth and -28dB RL, antenna operate from 3.4GHz to 14GHz and it is suitable for UWB, S-band applications [16]. Novel Ultrawideband planner monopole antenna is designed. It is operating from 3.1GHz to 10.8GHz and having a size of $12.5 \times 12.5 \times 1 \text{ mm}^3$ [17]. Proposed Antenna is multiband reconfigurable antenna for 5G wireless and CubeSat applications. Antenna is designed in low cost having less volume requirements and provides good isolation between wireless standard. [18]. Proposed manuscript presents a low-profile dual band patch antenna designed for mm-wave applications. Antenna have a dimension of $12 \times 3 \times .25 \text{ mm}^3$ it operates at 28GHz and 38GHz [19].

2. Materials And Methods

Microwave imaging uses ultra-wide band antenna to detect the tumour in brain. Circular microstrip patch antenna (CMPA) has been designed at 5.8GHz for ISM (Industrial Scientific and medical) band. CMPA is easy to fit for body part area due its shape. It is advantageous to use CMPA for microwave imaging so the signal reflected only from the effected part of the body. Initially CMPA is designed at 5.8GHz and radius of the CMPA has been calculated by the reference design equation given in [20] and it is designed on CST-MWS Studio 2014 [21]. Dielectric substrate used in the antenna is Rogers 5880 its dielectric constant is 2.2 and substrate height is chosen 0.800mm. Designed Circular microstrip patch antenna is shown in fig.1.

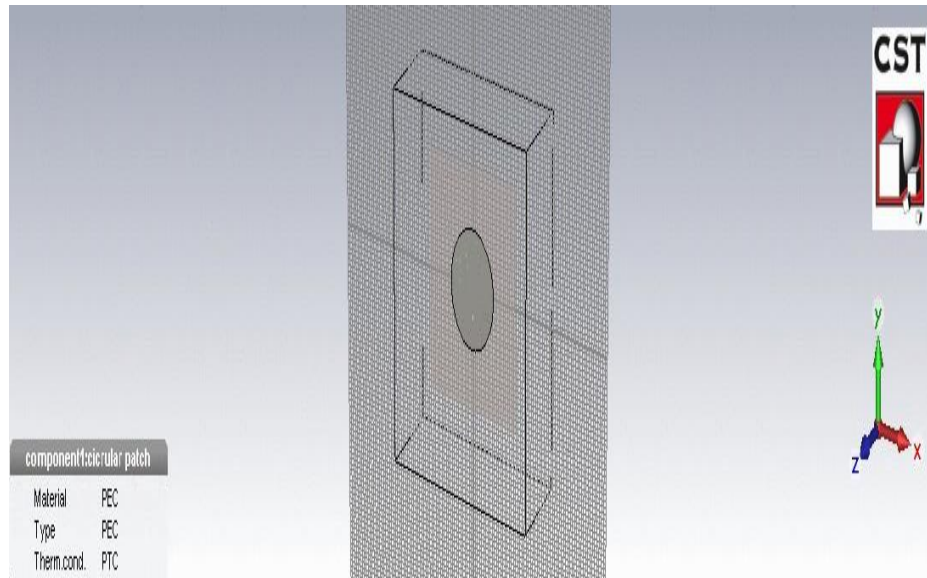

Figure.1. Circular Microstrip patch antenna

Designed CMPA in fig.1, gives return-loss 10.66dB and bandwidth 500MHz as shown in fig.2

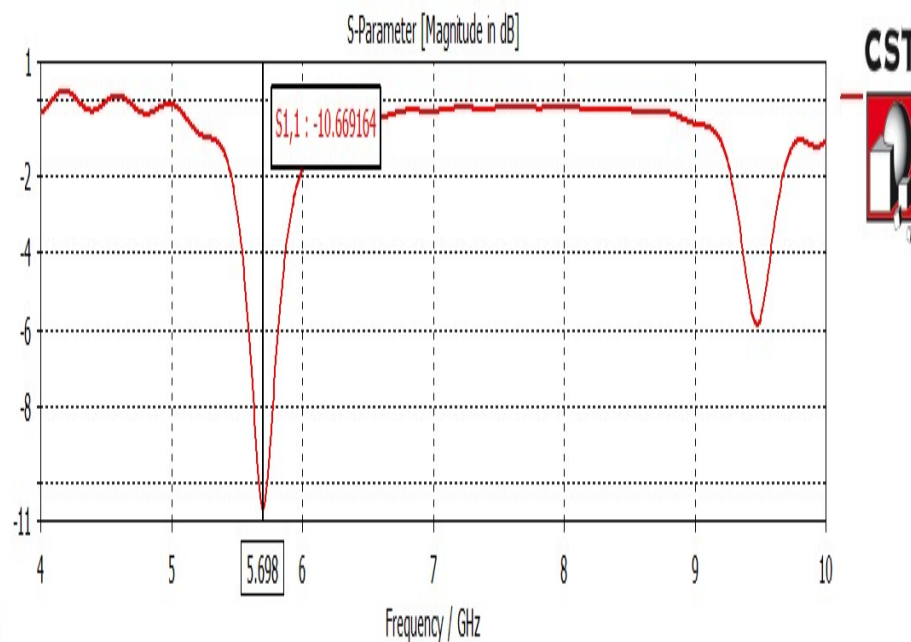

Figure.2. Return-loss of the designed CMPA at 5.8GHz

To make the designed antenna applicable for microwave imaging designed CMPA has to be converted into the ultra wideband antenna. CMPA converted into the ultra wideband planner antenna by applying different slit-slot inverted E-Shaped DGS (Defect Ground Structures) as shown in fig.3.

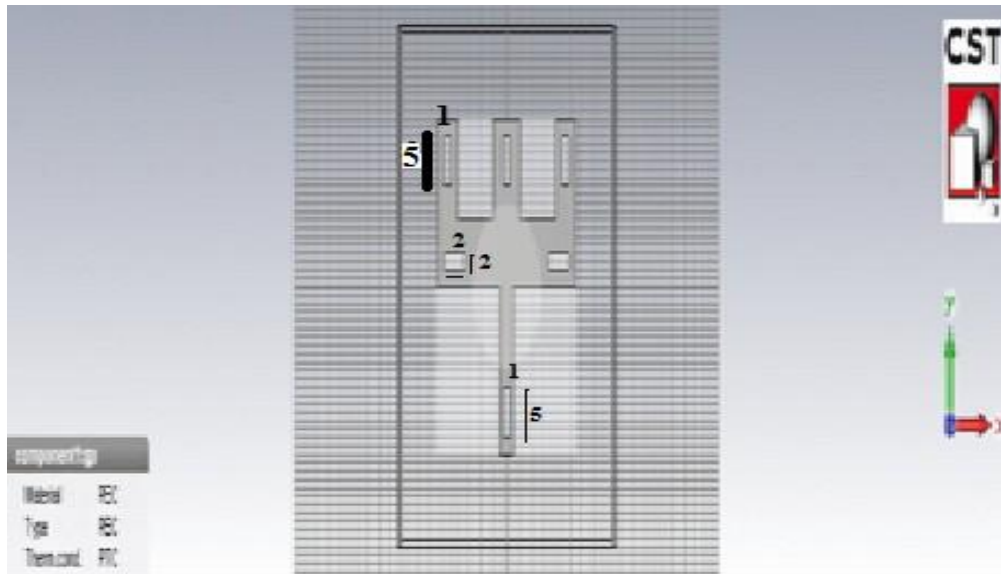

Figure.3. CMPA with nverted E shaped DGS dimensions

Return-loss and bandwidth of the CMPA with DGS given by the fig.4, all dimensions in fig.3 are in mm.

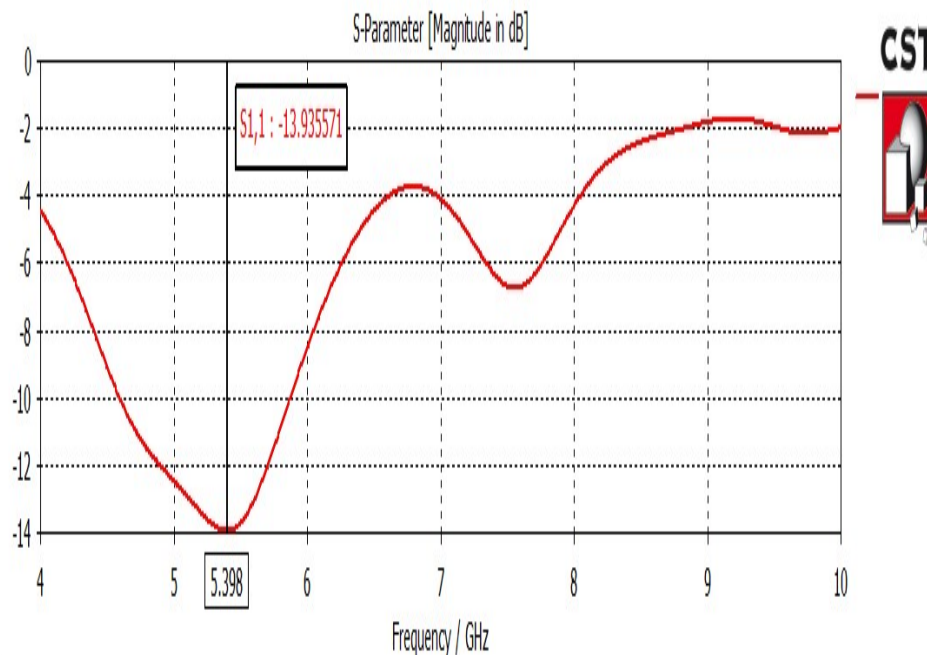

Figure4. Return-loss of CMPA with DGS is 13.9dB and bandwidth 1.5GHz

It is clear from figure 4 bandwidth of the antenna increased by 1 GHz and now antenna may be used for microwave imaging purpose.

2.1. Design of Multilayer brain phantom model

Multilayer brain phantom model is designed by considering the different layers of the brain with their relative dielectric constant. Brain has a different layers respectively names brain,CSF,dura.bone,fat,skin all the layers of the brain has been designed by taking different radius of the concentric spheres and their respective electrical parameter. Different layers of the brain and their electrical parameter given by the table given below.

Table.1 Dielectric properties of the different layers of the brain[13]

S.No	Name of the layer	Thickness	Permittivity(f/m)	Conductivity(s/m)
01	Skin	11	40.7	0.65
02	Fat	10	10	0.17
03	Bone	09	20.9	0.33
04	Dura	08	40.7	0.65
05	CSF	07	79.1	2.14
06	Brain	06	45.8	0.77

Designed multilayer brain phantom model is given by the Fig.5

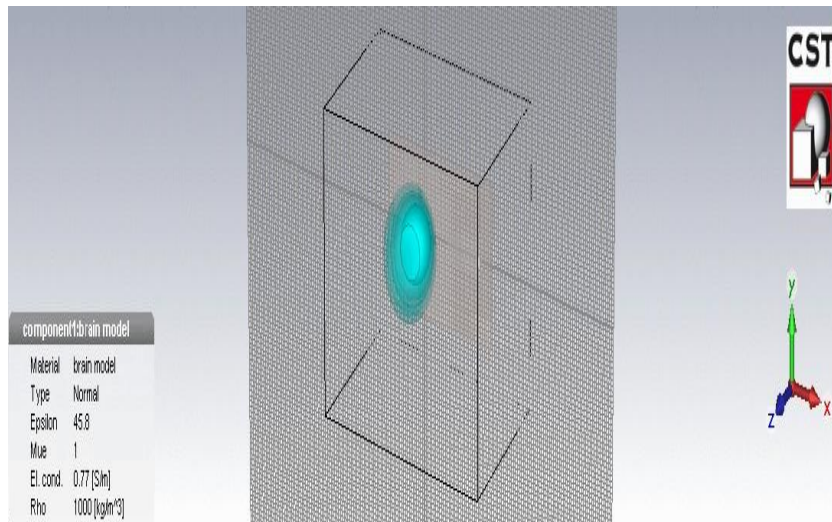

Figure.5. Designed multilayer brain phantom model

Designed multilayer brain phantom model is interfaced by the designed CMPA with DGS and all performance parameter of the antenna is given by the fig.6 to fig.9

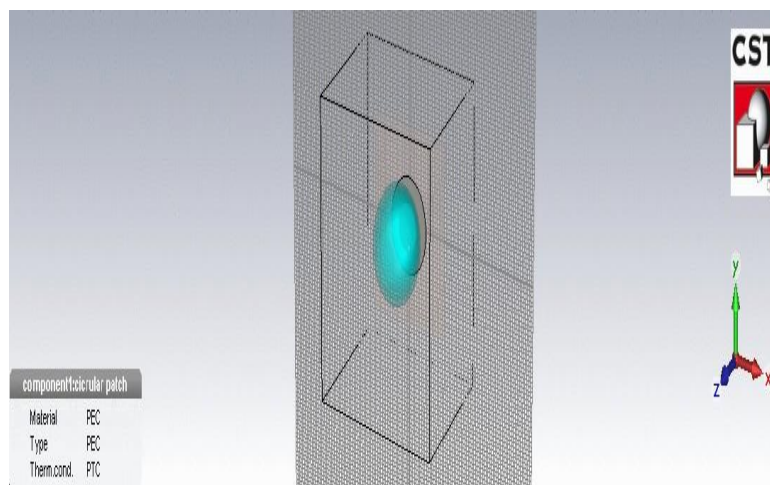

Figure.6. CMPA with Multilayer brain phantom model without tumor

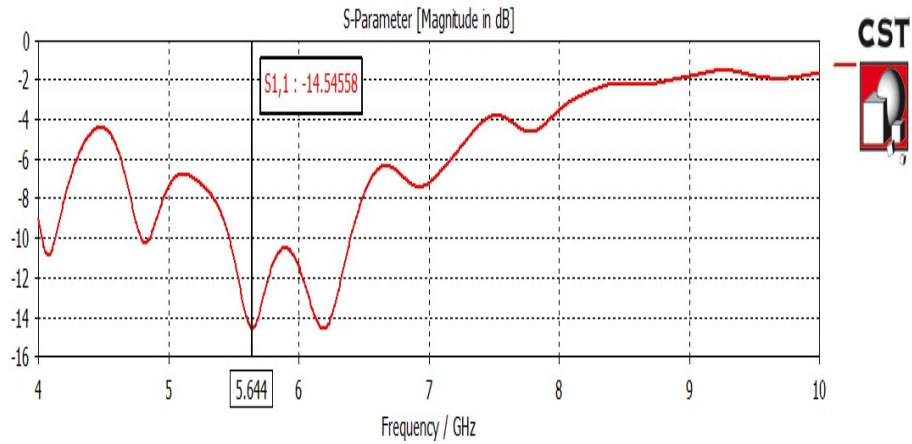

Figure.7. Returnloss of the CMPA with multilayer brain phantom model without tumor is 14.54dB at 5.644GHz

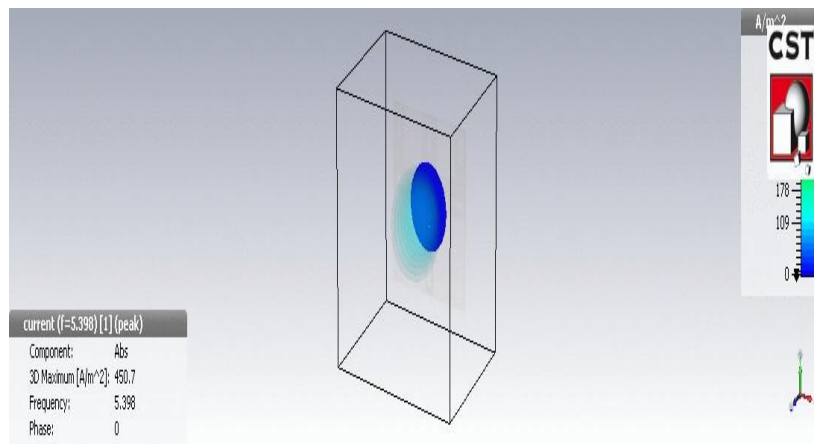

Figure.8. Current density of CMPA with Multilayer brain phantom model is given by 450.7A/m²

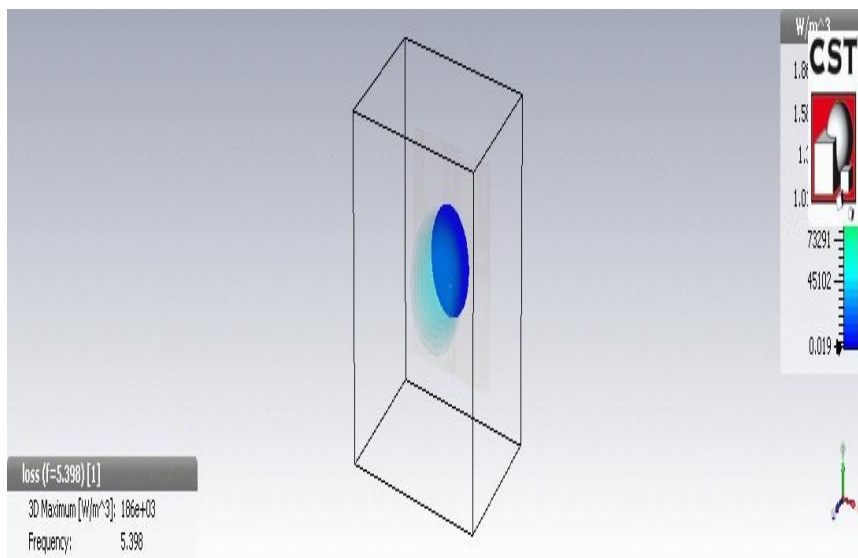

Figure 9. SAR of the CMPA with multilayer brain phantom model is given by 186e+03 W/m³

2.2. Spherical Shaped Tumor

Spherical shaped tumor has been designed by the sphere of some radius and its electrical properties are too chosen as cancer tumor. Spherical shaped tumor radius is chosen as 50mm and dielectric properties taken as dielectric constant =50f/m, conductivity=4s/m. CMPA with designed spherical shaped tumor is given by the figure.10

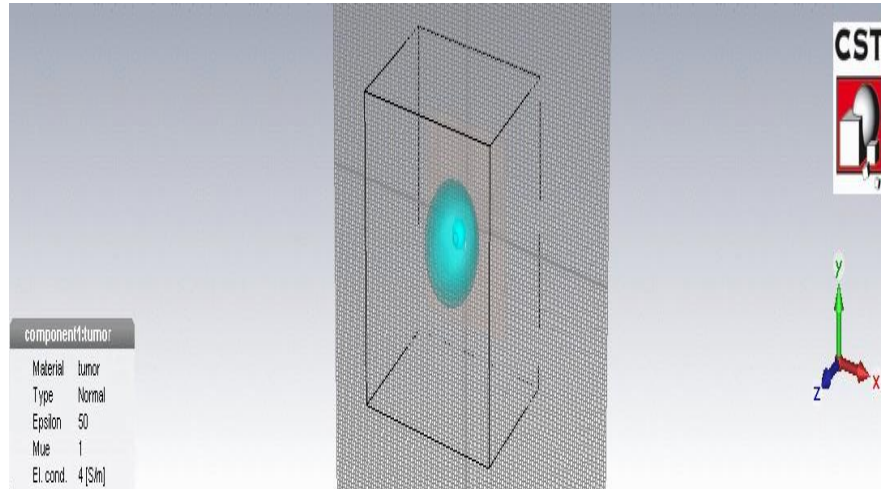

Figure.10. CMPA with Spherical shaped tumor

All performance parameter of the CMPA with multilayer brain phantom model and spherical shaped tumor given by the fig.11 to fig.13

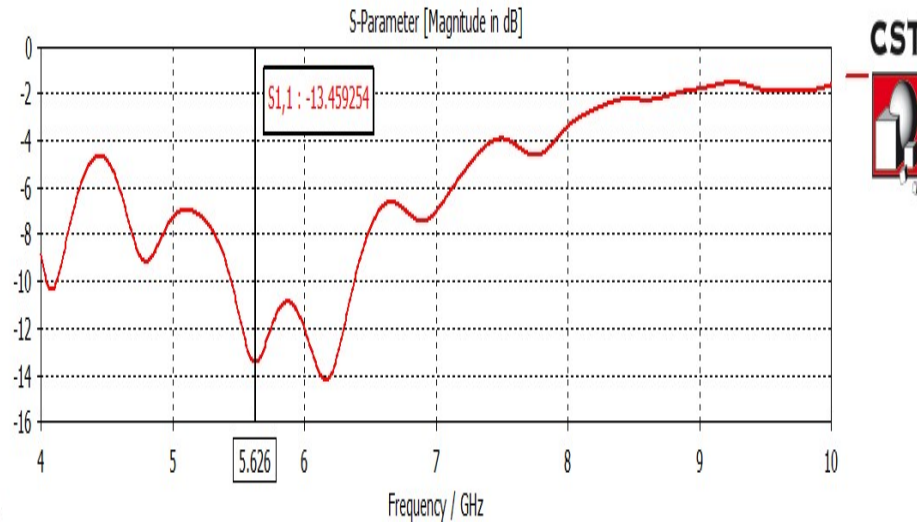

Figure.11. Returnloss of the CMPA with tumor is 13.45dB

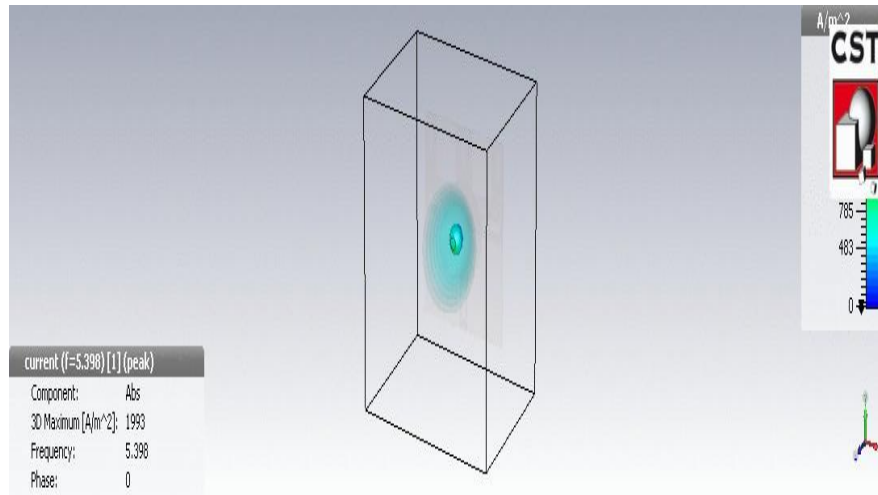

Figure.12. Current density of the CMPA with spherical shaped tumor is 1993A/m²

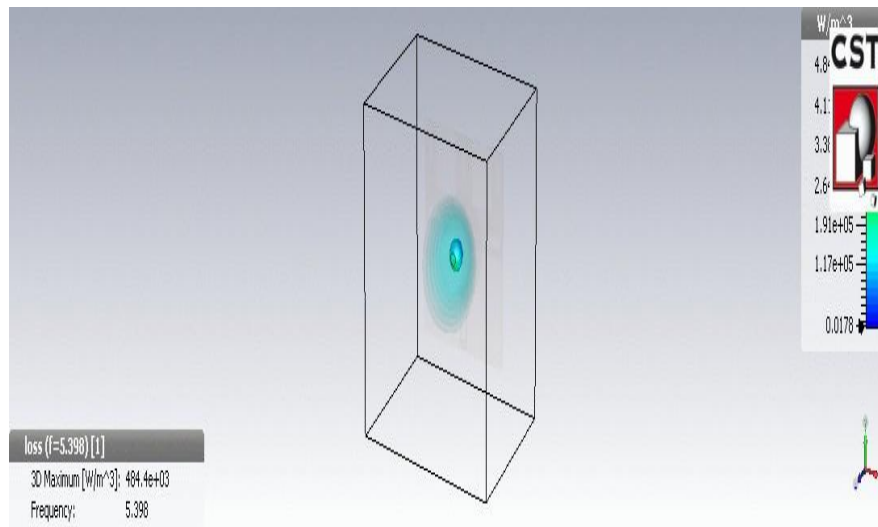

Figure.13. SAR of the CMPA with spherical shaped tumor is 484e+03 W/m³

As clear from fig. 11 and fig.7 return-loss of the CMPA with tumor is slightly decline shows the early presence of tumor. Figure 8 and Figure 12 shows the current density of the CMPA with tumor is increased it shows the early presence of tumor. Figure 9 and Figure 13 shows the SAR of the CMPA with tumor is also increased shows the early presence of tumor, it shows the early presence of tumor can be simultaneously detected by the three performance parameter of the antenna.

3.Results

Circular microstrip patch antenna is designed at 5.8GHz gives return-loss 10.66dB shown in fig.2. Inverted E shaped DGS is applied to the CMPA to make it ultra-wideband gives return-loss 13.9dB and bandwidth 1.5GHz shown in fig.4. Multilayer brain phantom model is shown in figure 5. Performance parameter of the CMPA without tumor is 14.54dB, 484A/m² and 186*10³W/m³ shown in fig.7-fig.9 respectively. Performance parameter of the CMPA with tumor is 13.45dB,1993A/m²,484*10³W/m³ shown in fig.11-fig.13 respectively. Increased Value of Current density, SAR with tumor truly shows the presence of the tumor. Decreased value of the return-loss with tumor also shows the presence of the tumor. Tumor is detected by the ultra wideband CMPA, circular antenna is also easy fit for body part due to its shape.

4. Conclusions

Circular Microstrip patch Antenna has been designed for ISM band at 5.8GHz so that the designed antenna can be used for biomedical application. After that DGS is applied to planner antenna to make it ultrawideband. CMPA is easily body fit antenna. Multilayer brain phantom model is designed on CST-MWS Simulation software by assuming dielectric constants for different layers of the brain. Tumor in brain model also assumed by the spherical shaped and its dielectric constant chosen according to the dielectric constant of the tumor. Increased value of SAR and Current density with and without tumor strongly shows the early presence of tumor.

References

1. Matteo (2010) ,“Microwave Imaging” Wiley Publication March.
2. Deschamps G.A(1953).,“Microstrip Microwave Antennas,” 3rd USAF Symposium on Antennas.
3. Shalini patel,souvik halder,Adarsh singh,debasis mitra,chaitali koley „Microwave based wearable sensors in for monitoring of tumors in different body part“in Results in Engineering Elsevier Vol.29 2026.
4. Jinu Mathew a , Osamah Ibrahim Khalaf b,* , Navin M George a,c , Ancy Michel a , Neethan Elizabeth Abraham a , Deema Mohammed Alsekait d,* , Sharf Alzu’bi e , Diaa Salama Abdelminaam “Microwave head imaging systems for early brain tumor detection: antenna designs and emerging substrates”in Methods(X) Elsevier 2025.
5. Huseyin Ozmen 1,2 , MengweiWu 2 and Mariana Dalarsson 2,* “Development of Wideband Circular Microstrip Patch Antenna for Use in Microwave Imaging for Brain Tumor Detection” in MDPI Sensors Vol.(26) 2026.
6. Jamlos1 M.A., Jamlos2 M.F., Ismail3 A.H (2015).“High-Performance Novel UWB Array Antenna for Brain Tumour Detection via Scattering Parameters” in Microwave Imaging Simulation System in Antennas and Propagation (EuCAP), 9th European IEEE Conference on 13-17 April pp 1-5.
7. Shrestha Sudhir, Agarwal Mangilal, Reid Joshua, and Varahramyan Kody (2008) “Microstrip Antennas for Direct Human Skin Placement for Biomedical Applications” in PIERS Proceedings, Cambridge, USA, July 5-8, pp 926-931.
8. Zhang Haoyu, O. El-Rayis Ahmed, Nakul Haridas, Nurul H. Noordin, Ahmet T. Erdogan, Tughrul Arslan.(2014) “A Smart Antenna Array for Brain Cancer Detection” in Loughborough Antennas & Propagation IEEE Conference 14-15 November, Loughborough, UK.
9. Radouane KARLII , Hassan AMMORI , Jamal EL AOUIFI (2014) “Miniaturized UWB Microstrip Antenna for Microwave Imaging” in WSEAS transactions on information science and applications Volume 11.
10. K. Sathiyasekar, N. Rajavinu, A. Prabha and C. Jayalakshmi (2016) “Analysis of brain tumour detection using intelligent techniques” in I.J.C.T.A, Vol.9 issue (5) , pp. 311-320.
11. E. Ricci, E. Cianca and T. Rossi (2015) Beam forming Algorithms for UWB Radar-based Stroke Detection: Trade-off Performance-Complexity in Journal of Communication, Navigation, Sensing and Services, Vol. 1, pp 11–28.
12. Amal Afyfl, Larbi Bellarbil, Anouar Achour1, Fatima Riouch2, Abdelhamid Errachid3A (2015) Novel Low Cost UWB Antenna for Early Breast Cancer Detection in American Journal of Electromagnetism and Applications Vol.3 issue (5) pp. 31-37.
13. Hemant Kumar Gupta,Raghvendra Sharma,Vandana Vikas Thakery (2017) “ Breast Cancer Detection by T-Shaped Slotted planner Antenna” in Indian Journal of Science and Technology vol.10 No.08 Feb. pp. 1-7.
14. Vinayagam, K., and R. Natarajan. "A Hybrid Mode Semicircular Shaped Frequency Reconfigurable Antenna for Multiband Communication." Scientific Reports 15 (2025): 34600.
15. Aziz, R. S., S. Koziel, and A. Pietrenko-Dabrowska. "A Compact Tri-band Omnidirectional Antenna Design for CubeSat Applications." Scientific Reports 15 (2025): 11908.
16. Yadav, Swati Varun, et al. "Miniaturized UWB Antenna Design for 5G and Space-based Microwave Applications." Results in Engineering 27 (2025): 105592.
17. Park, S., and K.-Y. Jung. "Novel Compact UWB Planar Monopole Antenna Using a Ribbon-Shaped Slot." IEEE Access 10 (2022): 61951-61959.
18. Ramahatla, K., et al. "Multiband Reconfigurable Antennas for 5G Wireless and CubeSat Applications: A Review." IEEE Access 10 (2022): 40910-40931.
19. Tiwari, Rakesh N., et al. "A Low-profile Dual-band Millimetre Wave Patch Antenna for High-speed Wearable and Biomedical Applications." Results in Engineering 24 (2024): 103212.
20. C.Balinies (1997), “Antenna Theory”, Wiley, 2nd addition chapter -14 ISBN 0-471- 59268-4.
21. <http://www.cst.com/content/products/mws/overview.aspx> © 2012 CST Computer Simulation Technology. (2012).